



# **Aviation Standard WindObserver with Enhanced Heating Ultrasonic Anemometer**

## **User Manual**

**Doc No. 1390-PS-0019  
Issue 1**

**APPLIES TO UNITS WITH PART NUMBER  
1390-PK-079**

**Gill Instruments Limited**

Saltmarsh Park,  
67 Gosport Street,  
Lymington,  
Hampshire.  
SO41 9EG  
UK

Tel: +44 (0) 1590 613500  
Fax: +44 (0) 1590 613501  
E-mail: [anem@gill.co.uk](mailto:anem@gill.co.uk)  
Website: [www.gill.co.uk](http://www.gill.co.uk)



Aviation Standard WindObserver Anemometer

# Contents

<b>1.</b>	<b>FORWARD .....</b>	<b>5</b>
<b>2.</b>	<b>INTRODUCTION.....</b>	<b>5</b>
<b>3.</b>	<b>FAST TRACK SET-UP .....</b>	<b>5</b>
<b>4.</b>	<b>SPECIFICATION .....</b>	<b>6</b>
<b>5.</b>	<b>PRE-INSTALLATION .....</b>	<b>7</b>
5.1.	Equipment supplied .....	7
5.2.	Installation requirements.....	7
<b>6.</b>	<b>INSTALLATION.....</b>	<b>8</b>
6.1.	Installation Guidelines.....	8
6.2.	Bench system test .....	9
6.3.	Cabling .....	9
6.4.	Connections.....	10
	Default Settings.....	11
	Connecting to a PC with a RS422 or RS485 input .....	11
	Networking units .....	12
6.5.	Indoor Power and Communications Interface (Part 1189-PK-021).....	13
	Connecting to a PCI Unit with RS422 input.....	13
	PCI Electrical Power Requirements.....	13
	PCI Connector Pin and Cable assignments .....	14
	Anemometer connector – 15 way .....	14
	Auxiliary Analogue Outputs – 9 way .....	14
	DC Supply – 4 way .....	14
	RS 232 Output – 9 way.....	15
	RS422 Network In – 9 way Skt.....	15
	RS422 Network Out – 9 way Plg .....	15
6.6.	Power supplies .....	16
6.7.	Mechanical installation.....	17
	Location.....	17
	Orientation .....	17
	Mounting bracket .....	17
	Alignment .....	19
	Figure 2a North marker and UV polarity definition (UV format) and Mounting Ring	19
	Figure 2b Aviation Standard WindObserver outline dimensions .....	20
<b>7.</b>	<b>USING WITH THE GILL WINDDISPLAY .....</b>	<b>21</b>
	Connecting to a Gill WindDisplay .....	22
<b>8.</b>	<b>MESSAGE FORMATS &amp; OPTIONS.....</b>	<b>23</b>
8.1.	Wind Speed format .....	23
8.2.	Output formats.....	23
	Low wind speeds .....	23
8.3.	Networking.....	24
8.4.	Units .....	25
8.5.	Output rate.....	25
	Sample Average .....	25
8.6.	Averaging (Digital Data).....	25
8.7.	Heating .....	25
8.8.	45° Offset.....	25
8.9.	Vertical Output Padding .....	25
8.10.	ASCII message format (UV and Polar) .....	26
	ASCII UV format .....	26

ASCII Polar format .....	27
8.11. NMEA Format .....	28
<b>9. CONFIGURING.....</b>	<b>29</b>
9.1. Entering Configuration mode .....	29
9.2. Returning to Measurement mode.....	29
9.3. Checking the configuration .....	30
9.4. Changing settings .....	30
9.5. Configuration Settings.....	30
Ax – Not Applicable.....	30
BX - Baud Rate .....	31
Cx- Not applicable.....	31
Dx- Diagnostic and Configuration Command (see also Section 10.6) .....	31
Ex - Full Duplex/Half Duplex Mode .....	32
Fx- Data and Parity Options .....	32
Gx to Gxxxx - Averaging (Digital Outputs only) .....	32
Hx - Heating .....	32
Jx - Not applicable .....	32
Kx – NMEA Settings .....	32
Lx - ASCII Message Terminator .....	32
Mx to Mxx - Message Format .....	33
Nx - Node Address.....	33
Ox – ASCII Output Format (Output String Padding).....	33
Px - Output Rate .....	33
Q- Measurement Mode .....	33
Tx - Not Applicable.....	34
Ux – Digital Output Units.....	34
Vx- Vertical Output Padding.....	34
Xx - 45° Alignment Offset/Inverted Operation .....	34
Yx – Not Applicable.....	34
Zx – Not Applicable.....	34
<b>10. MAINTENANCE &amp; FAULT-FINDING .....</b>	<b>35</b>
10.1. Cleaning and Handling.....	35
10.2. Servicing .....	35
10.3. Fault-finding .....	35
10.4. Returning units.....	36
10.5. Status (error) codes .....	36
10.6. Bench test.....	37
Integrity & Zero Wind Check.....	37
<b>11. APPENDICES.....</b>	<b>39</b>
11.1. Glossary & Abbreviations.....	39
11.2. Guarantee.....	40
11.3. Principle of operation .....	41
11.4. Electrical Conformity.....	42

## 1. FORWARD

Thank you for purchasing the Aviation Standard WindObserver with Enhanced Heating manufactured by Gill Instruments Ltd.

The unit has no customer serviceable parts and requires no calibration or maintenance. To achieve optimum performance we recommend that you read the whole of this manual before proceeding with use. Do **NOT** remove black “rubber” transducer caps.

Gill products are in continuous development and therefore specifications may be subject to change and design improvements without prior notice.

The information contained in this manual remains the property of Gill Instruments and should not be copied or reproduced for commercial gain.

## 2. INTRODUCTION

The Gill Aviation Standard WindObserver has been accepted for service by both the Federal Aviation Administration (USA) and the Civil Aviation Authority (UK) for the observation and reporting of surface wind. The Aviation Standard WindObserver meets the requirements of Annex 3 to the Convention on International Civil Aviation Organisation (ICAO) when supplied as part of an Automatic Weather Observing System (AWOS).

The Aviation Standard WindObserver wind sensor is a very robust, lightweight unit with no moving parts, outputting wind speed and direction. The units of wind speed, output rate and formats are all user selectable.

The Aviation Standard WindObserver is available with enhanced de-icing heating (recommended if severe icing is likely).

The Aviation Standard WindObserver can be used in conjunction with a PC, data logger or other device, provided it is compatible with the RS422 output. Multiple units can be networked if required.

Alternatively, the Aviation Standard WindObserver is designed to connect directly to the Gill WindDisplay unit to provide a complete wind speed direction system without any configuration required by the user.

The output message format can be configured in Polar, UV (2-axis), NMEA (0183 Version 3), Tunnel formats, and as either a Continuous output or Polled (requested by host system), detailed in full in Section 8 Message Formats & Options.

Aviation Standard WindObserver may be configured using WindCom software which is available, free of charge, from the Gill website [www.gill.co.uk](http://www.gill.co.uk), or by using standard communications software on a PC. This is explained in Section 9 Configuring.

## 3. FAST TRACK SET-UP

If you are in a hurry to try out the Aviation Standard WindObserver, are familiar with Gill equipment, and coupling to a PC using RS422, go to the following sections:

*Section 6 Installation*

*Section 8 Message Formats & Options*

*Section 9 Configuring*

After you have successfully set up the Aviation Standard WindObserver, we strongly advise that you then go back and read the rest of the manual to ensure that you get the best results from the Aviation Standard WindObserver.

## 4. SPECIFICATION

<b>Measurement</b>	
Output	1, 2, 4 Hz
Parameters	UV, Polar, NMEA
Units	m/s, Knots, MPH, KPH ft/min
Averaging	Flexible 1-3600 seconds
<b>Wind Speed</b>	
Range	0 - 75m/s
Accuracy	±2%@12m/s
Resolution	0.01m/s
Offset	±0.01m/s
<b>Direction</b>	
Range	0 - 359°
Accuracy	± 2°
Resolution	1°
<b>Anemometer Status</b>	Supplied as part of standard message
<b>Starting Threshold</b>	0.01 m/s
<b>Dead Band Wind Direction</b>	None
<b>Power Requirement</b>	
Anemometer only	20-30 V DC 50mA average, reverse voltage protected
Heating - Optional	Allow for 7A @ 24v AC rms ± 15%, or 24v DC± 10%.
<b>Digital Output</b>	
Communication	RS422, full duplex, network facility
Baud rates	1200, 2400, 4800, 9600, 19200, 38400
Formats	8 data, odd, even or no parity
<b>Dimensions</b>	
Size	381mm x 213mm
Weight	1.4kg (no cable)
<b>Materials</b>	
External Construction	Stainless Steel 316
<b>Environmental</b>	
Moisture protection	IP66 (NEMA4X)
Operating temperature	-55°C to +70°C, heating on
Humidity	0% to 100% RH
Precipitation	300mm/hr
EMC	EN 61326-1: 2006 EN 55011:2007
Icing	MIL STD 810F Method 521.1 Procedure 1
<b>Standards</b>	Traceable to UK national standards
<b>Site Calibration</b>	None required. (See Section 10.6 Zero Wind Check)

### WARNING NOTE:-



**When heating is activated the bullet and transducer arms will get very hot and should not be handled.**

## 5. PRE-INSTALLATION

### 5.1. Equipment supplied

- Aviation Standard WindObserver RS422 output and de-icing.
- and Installation kit (comprising a gasket and four Stainless Steel screws).
- and Aviation Standard WindObserver User Manual (this manual)
- and Integrity Check Chamber (ICC) (Optional)

### 5.2. Installation requirements

**Host system** - One of the following:

- PC with an internal or external interface compatible with the RS422 output from the Aviation Standard WindObserver.
- Gill WindDisplay.
- Other equipment with I/O compatibility to the WindObserver Aviation Standard. For example if the unit has Digital outputs, a Data Logger, Chart Recorder, or PC.
- Networking - Multiple Aviation Standard WindObserver units can be networked

**Software** - One of the following:

- WindCom – A user-friendly package providing easy configuring of the Aviation Standard WindObserver, for use on PCs running under Windows™ 98, 2000 or XP. Available to customers as a free download from [www.gill.co.uk](http://www.gill.co.uk).
- HyperTerminal (for Windows™ 9x and later), or Terminal (Windows™ 3.n), normally already installed on a PC.
- Other Terminal Emulation software packages

#### **Cable and Junction box**

To connect between the Aviation Standard WindObserver and the host system. The unit is supplied with a flying cable, requiring a mast mounted junction box (not provided) for onward connection.

The flying cable must be retained with a cable tie within 150mm of the base of the anemometer.

#### **Mounting Bracket**

A mounting bracket is required (not provided) which will attach to the Aviation Standard WindObserver via the four tapped holes in the base of the unit. Always ensure that the gasket supplied is fitted to the base of the anemometer.

It is important that the gasket supplied forms a watertight seal on the base of the anemometer.

In the event that the mounting bracket supplied by the customer is not flat or does not form complete support for the anemometer base; the customer must fit a mounting ring as shown in Figure 2.

## 6. INSTALLATION

**Do NOT remove the black “rubber” transducer caps. Warranty is void if the Red security seal is damaged or removed.**

**Take care not to knock the four Transducer arms. All the time the Aviation Standard WindObserver is not in its final location, it should be protected from damage by keeping it in the original packaging as long as possible, treating it as a delicate instrument.**

**If an Intrinsically Safe (IS) device is required, the I.S. WindObserver must be used - the Aviation Standard WindObserver is NOT an IS device.**

### 6.1. Installation Guidelines

The Aviation Standard WindObserver has been designed to meet and exceed the stringent standards listed in its specification. Operating in diverse environments all over the world, Aviation Standard WindObserver requires no calibration or adjustment whatsoever.

As with any sophisticated electronics, good engineering practice should be followed to ensure correct operation.

- Always check the installation to ensure the Aviation Standard WindObserver is not affected by other equipment operating locally, which may not conform to current standards, e.g. radio/radar transmitters, boat engines, generators etc.

Guidelines –

- Avoid mounting in the plane of any radar scanner – a vertical separation of at least 2m should be achieved.
- Radio transmitting antennas, the following minimum separations (all round) are suggested
  - VHF IMM – 1m
  - MF/HF – 5m
  - Satcom – 5m (avoid likely lines of sight)
- Ensure the product is correctly earthed in accordance with this manual
- Use cables recommended by Gill, keeping the length below the maximum allowed (*See Section 6.3*) Where the cables are cut and re-connected (junction boxes, plugs and sockets) the cable screen integrity must be maintained, to prevent the EMC performance being compromised.
- Earth loops should not be created – earth the system in accordance with the installation guidelines. (*See Section 6.4*)
- Ensure the power supply operates to the Aviation Standard WindObserver specification at all times.

Avoid turbulence caused by surrounding structures that will affect the accuracy of the Aviation Standard WindObserver such as trees, masts and buildings. The World Meteorological Organisation makes the following recommendation:

- The standard exposure of wind instruments over level open terrain is 10m above the ground. Open terrain is defined as an area where the distance between the sensor and any obstruction is at least 10 times the height of the obstruction.

When installing the unit degrease the unit and hold with lint free gloves to reduce the build up of deposits.

## 6.2. Bench system test

***Note:** Prior to physically mounting the Aviation Standard WindObserver in its final location, we strongly recommend that a bench system test be carried out to confirm the system is configured correctly, is fully functional and electrically compatible with the selected host system and cabling (preferably utilising the final cable length). The required data format, units, output rate, and other options should also all be configured at this stage. If an Integrity Check Chamber (ICC) has been purchased refer to Section 10.6.*

## 6.3. Cabling

### Cable type

A RS422 compatible cable should be used, with the number of twisted pairs matching the application.

**Generic description** – Twisted pairs with drain wire, screened with aluminised tape, with an overall PVC sheath. Wire size 7/0.2mm (22 or 24 AWG)

The table shows some suitable manufacturers' references; other manufacture's equivalents can be used.

**Table 1**

No. of pairs	Gill ref.	Belden ref.	Batt electronics ref.
2	-	9729	91071
3	026-02660	9730	91030
4	026-03156	9728	91199
6	-	8778	91011
9	026-02663	8774	91009

### Cable length

The typical maximum length at 9600 baud is 1km (3200ft), using the recommended cable. If any problems of data corruption are experienced (due to, for example, a high local electrical 'noise' level), then a lower baud rate should be used. Alternatively, a thicker or higher specification cable can be tried.

### Cabling and junction box

The Aviation Standard WindObserver unit is fitted with a flying 9 pair cable attached. This must be terminated in a suitable terminal box to IP66 or better, fitted with glands to prevent moisture ingress.

The cable type from the terminal box to the host system must be as specified above. If any cable is likely to be exposed to mechanical damage, it must be enclosed in a suitable conduit or cable tray. The cable must be securely fixed with cable clamps or equivalent, such that the cable is not under stress at the Aviation WindObserver cable gland or terminal box glands.

The gland area at the base of the Aviation Standard WindObserver **should not** be directly exposed to moisture, as whilst the gland is sealed when mated, the anemometer is vented to air at the base to avoid pressure build up. If an IP66 rating is essential or the unit is mounted other than 'right way up' **use the gasket** provided in the mounting kit.

## 6.4. Connections

**Important** Any cores not used should be isolated.

**Do NOT connect the unit's 0V, heating –ve, or digital 0V to the screen or earth.**

The screens of each pair are joined together inside the anemometer - these should be joined to the cable screen(s) of any further cable run. Avoid long grounding loops. Digital 0V should be used in conjunction with RS422 TX RX lines in order to improve noise immunity. Each pair in the cable is labelled with its pair number.

**Table 2**

Conductor colour		Designation
Pair 1	green	RS422_TXB (+)
	black	RS422_TXA (-)
Pair 2	white	RS422_RXB (+)
	black	RS422_RXA (-)
Pair 3	red	Supply V+
	black	Supply V-
Pair 4	blue	Digital 0v
	black	Not used (isolate)
Pair 5	yellow	Heater +
	black	Heater –
Pair 6	brown	Heater +
	black	Heater –
Pair 7	orange	Heater +
	black	Heater –
Pair 8	white	Not used (isolate)
	red	Not used (isolate)
Pair 9	green	Not used (isolate)
	red	Not used (isolate)
Screens		Chassis ground

### Earthing or grounding

To ensure correct operation, and for maximum protection against lightning, the anemometer **MUST** be correctly earthed (grounded) via its mountings. Inadequate Earthing will degrade anemometer performance, particularly in the presence of radio frequency interference.

*See Fig 1 Suggested mounting bracket and Earthing (grounding) arrangements*

The unit **MUST** be connected to an appropriate grounding point with a minimum of 6mm<sup>2</sup> copper wire, via the M5 base screws. The cable screens must be joined with any cable screen continuing from the unit's cable via a junction box. The primary earth for the anemometer must be provided via the base screws and not via the cable screens.

## Default Settings

The factory default settings are:

A0 B3 C1 E1 F1 G0000 H1 J1 K1 L1 M2 NA O1 P1 T1 U1 V1 X1 Y1 Z1

**Note** that the Heating (H Command) is not enabled as a default condition. If heating is required then the H command must be set for H2.

*See Section 9 Configuring for further details.*

## Connecting to a PC with a RS422 or RS485 input

The PC requires either an internal RS422 interface card, or an external RS422/485 to RS232 converter, which will plug into the standard 9 way or 25 way RS232 serial port of the PC or host equipment.

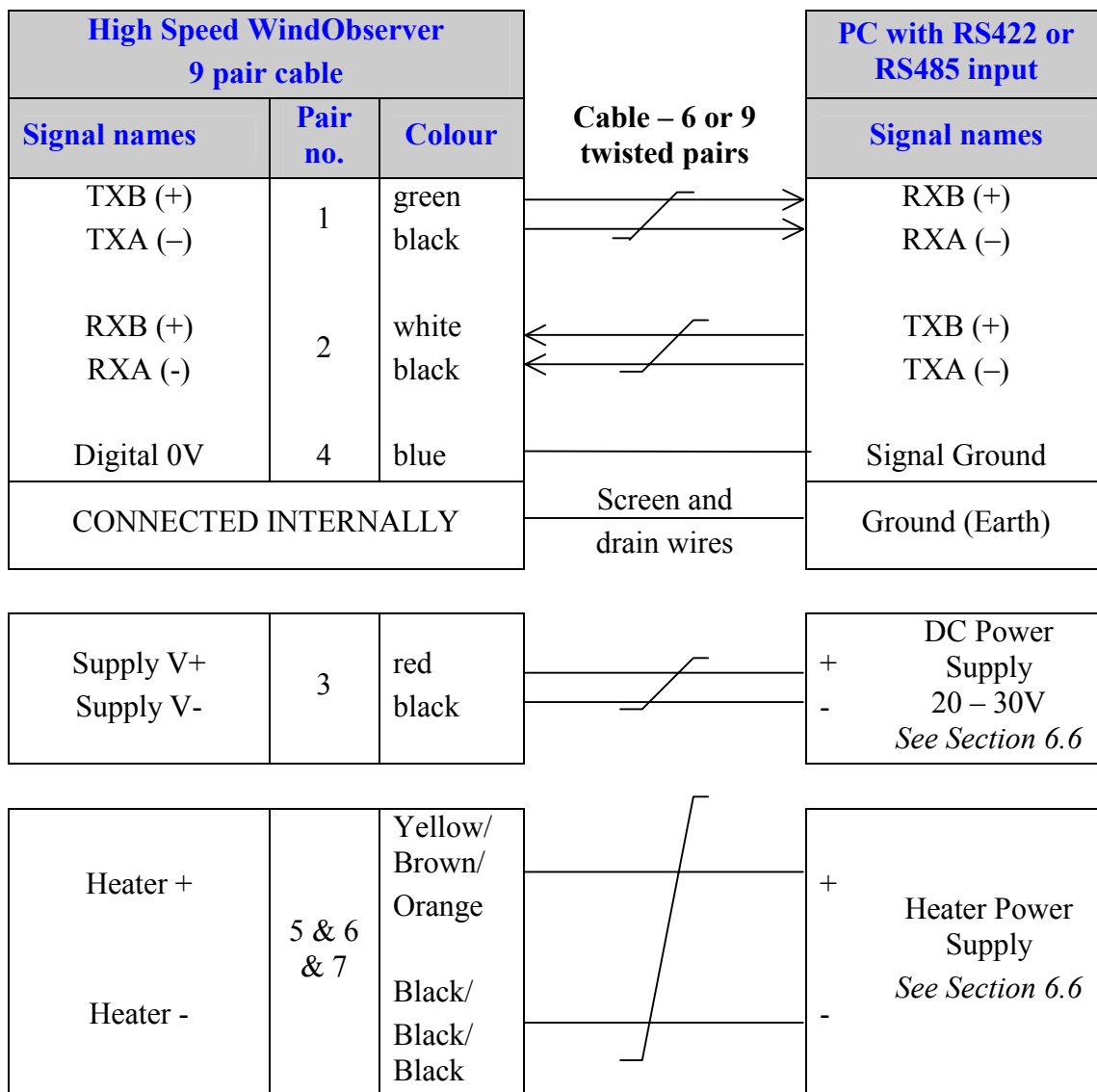

**Note:-**

Heater Pair wires Yellow, Brown and Orange should be connected in Parallel, as too should the return 3 Black wires.

## Networking units

Before coupling units into a network:

- Each device must be configured with a unique Unit Identifier (letter A to Z) however in multi drop systems it could be advised to avoid using letters A-F, K,M,N and P as they could appear in the data string.
- Unit must be set for half duplex mode (E2 setting) see Para 8.3).
- It must be configured to a tri-state polled mode [M3](#) or [M4](#).

*See also Section 9 - Configuring*

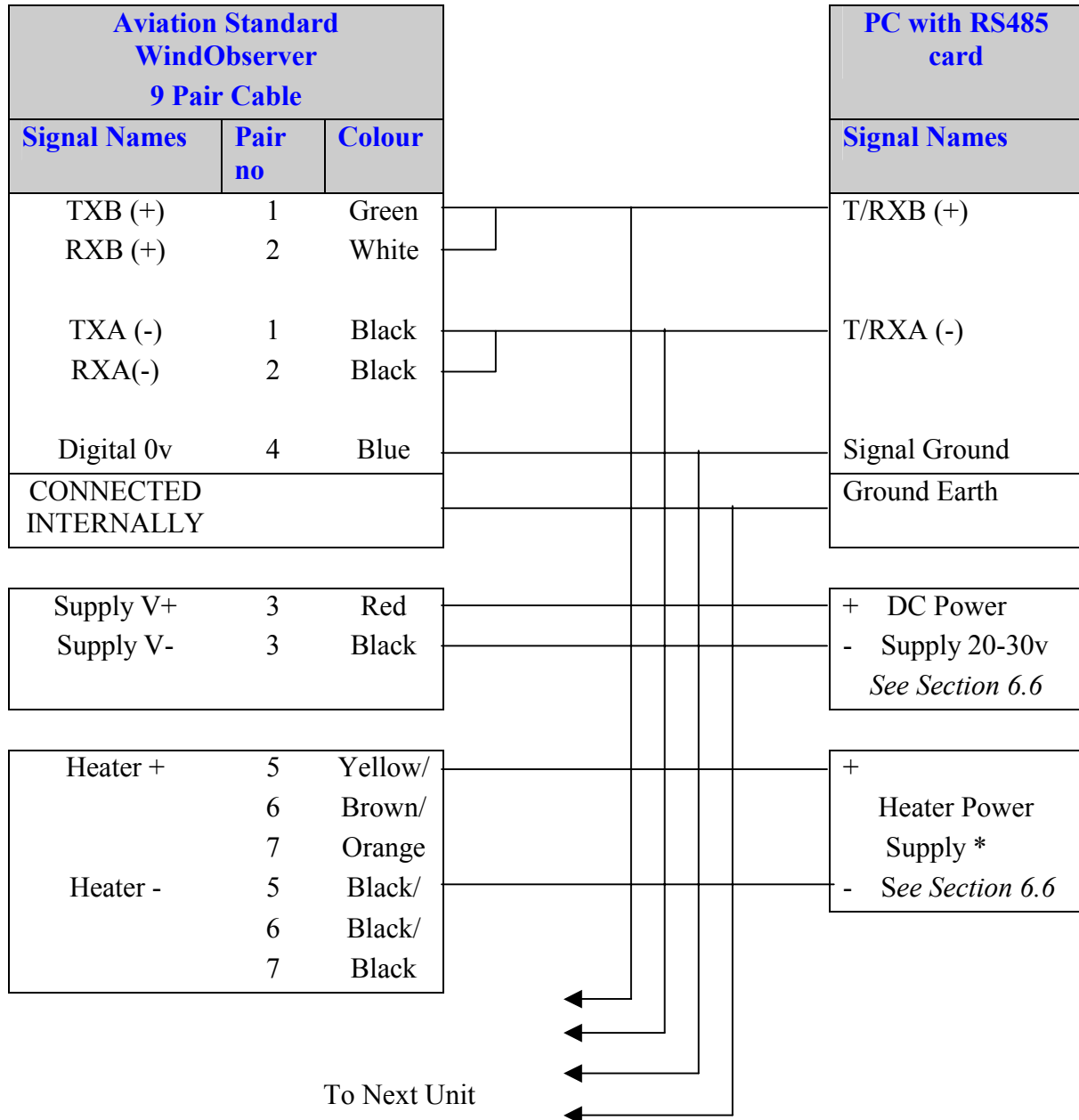

### Notes:-

Heater Pair wires Yellow, Brown and Orange should be connected in Parallel, as too should the return 3 Black wires.

Each unit in the network will require its own power supplies. Please refer to section 8.3.

## 6.5. Indoor Power and Communications Interface (Part 1189-PK-021)

The desktop PCI is intended for use in a protected environment and provides interfacing and power to a single anemometer (Note a separate supply is required for heating).

The PCI is not intended for outdoor use.

### Connecting to a PCI Unit with RS422 input

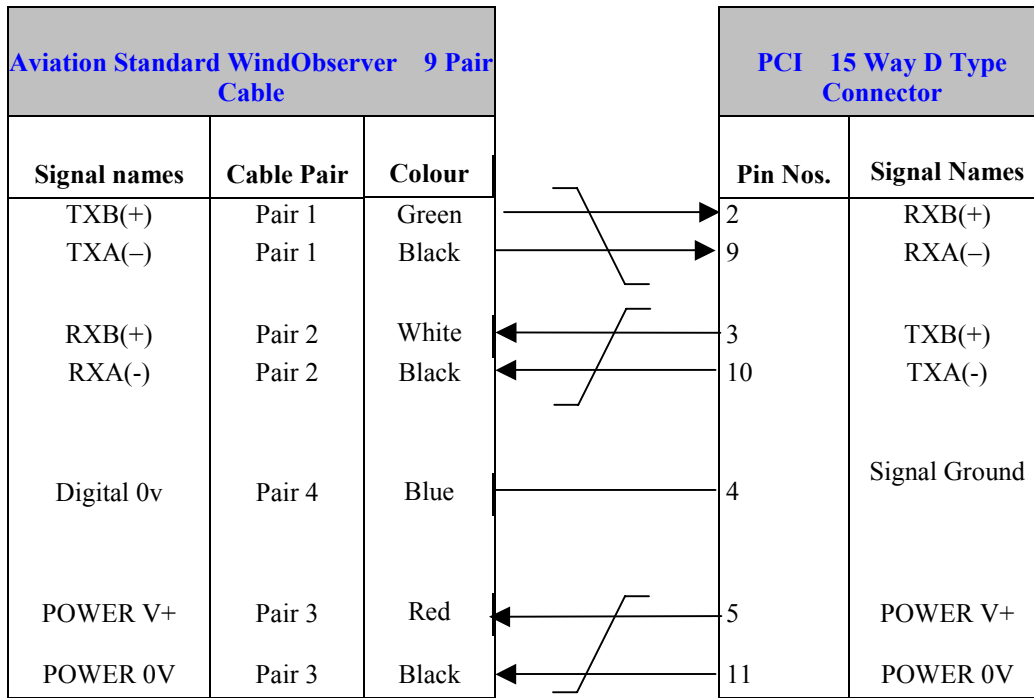

To Connect the PCI RS232 Output (9 Pin D Type connector) to a PC RS232 9 way port to communicate with the sensor connect as follows:-

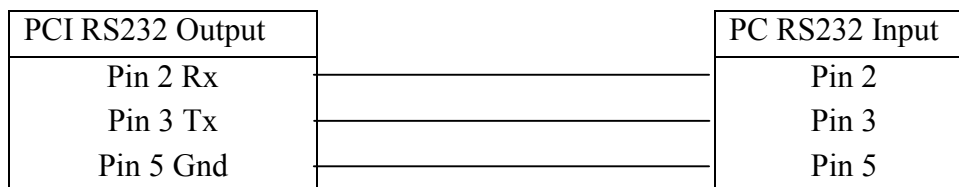

### Environmental

#### PCI Electrical Power Requirements

- 1) 100Vac – 120Vac, 10VA for the 115V switch position
- 2) 200 Vac – 250Vac, 10VA for the 230V switch position
- 3) 20-30Vdc, 120mA max (anemometer)  
8-15Vdc, 50mA max (interface)

3 Fuses protect the unit:

1. Externally accessible 315mA(T) for 115/230v operation
2. Internally accessible 500mA (T) AUX
3. Internally accessible 500mA (T) ANEM

## PCI Connector Pin and Cable assignments

### Anemometer connector – 15 way

<b>Pin</b>	<b>Designation</b>
1	Chassis
2	RS422_RXB (+)
3	RS422_TXB (+)
4	Digital 0V, Signal ground
5	Supply V+
6	Analogue output V1
7	Not used
8	Analogue output V2
9	RS422_RXA (-)
10	RS422_TXA (-)
11	Supply V-
12	Analogue output V4
13	Analogue 0V
14	Not used
15	Analogue output V3

### Auxiliary Analogue Outputs – 9 way

<b>Pin</b>	<b>Designation</b>
1	Earth
2	Analogue Ground 1
3	Analogue Ground 2
4	Analogue Ground 3
5	Analogue Ground 4
6	Analogue Output 1 (direct connection to Anemometer Connector Pin 6)
7	Analogue Output 2 (direct connection to Anemometer Connector Pin 8)
8	Analogue Output 3 (direct connection to Anemometer Connector Pin 15)
9	Analogue Output 4 (direct connection to Anemometer Connector Pin 12)

### DC Supply – 4 way

<b>Pin</b>	<b>Designation</b>
1	Interface V+
2	Interface V-
3	Anemometer V-
4	Anemometer V+

**RS 232 Output – 9 way**

<b>Pin</b>	<b>Designation</b>
1	DCD
2	RX data
3	TX data
4	DTR
5	Signal Ground
6	DSR
7	RTS
8	CTS
9	RI

**RS422 Network In – 9 way Skt**

<b>Pin</b>	<b>Designation</b>
1	Not connected
2	Not connected
3	Not connected
4	RS422_RXA (-)
5	Signal ground
6	RS422_TXA (-)
7	RS422_TXB (+)
8	RS422_RXB (+)
9	Chassis

**RS422 Network Out – 9 way Plg**

<b>Pin</b>	<b>Designation</b>
1	Not connected
2	Not connected
3	Not connected
4	RS422_RXA (-)
5	Signal ground
6	RS422_TXA (-)
7	RS422_TXB (+)
8	RS422_RXB (+)
9	Chassis

## 6.6. Power supplies

### Aviation Standard WindObserver units

#### Sensor Supply: -

Voltage	20v to 30v DC
Current	60mA max. 50mA average

- The Aviation Standard WindObserver has reverse polarity protection.

### Aviation Standard WindObserver Heating

#### Heater Supply: -

Voltage	24V $\pm$ 15% AC RMS or 24V DC $\pm$ 10%.
Current	allow for 7A.

- **The AC Supply must be isolated from Mains Supply.**
- The heating module requires a separate power supply.
- Heater Cable length should be minimised to avoid cable volt drops and ensure maximum voltage received at the Anemometer.
- All three heater pair cables must be used, connect yellow, brown and orange wires to heater positive and their respective black wires to heater negative.
- The heating (H command) is not enabled as a default condition. If heating is required enabled then the H command must be set for H2 or H3.

The Aviation Standard WindObserver has reverse polarity protection.

#### **WARNING NOTE:-**



**When heating is activated the bullet and transducer arms will get very hot and should not be handled.**

## 6.7. Mechanical installation

**Do NOT remove the black “rubber” transducer caps. Warranty is void if the Green security seal is damaged or removed.**

**Take care not to knock the four Transducer arms.**

**Before installing, a bench system test is recommended.**

**All the time the Aviation Standard WindObserver is not in its final location, it should be protected from damage by keeping it in the original packaging as long as possible, treating it as a delicate instrument.**

**When installing the unit handle with lint free gloves and degrease the unit to reduce the build up of deposits.**

### Location

It is important to ensure that the Aviation Standard WindObserver is mounted in a position clear of any structure, which may obstruct the airflow or induce turbulence.

Do NOT mount the Aviation Standard WindObserver in close proximity of high-powered radar or radio transmitters. A site survey may be required if there is any doubt about the strength of external electrical noise. (*See Section 6.1*)

### Orientation

Normally the Aviation Standard WindObserver is mounted vertically with the cable exit at the bottom.

Alternatively, the unit may be mounted in any orientation, but note that if the unit is mounted with the cable uppermost, the gasket provided in the mounting kit **must** be used.

### Mounting bracket

A suggested mounting bracket is shown in Fig 1.

It is recommended that the Aviation Standard WindObserver mounting bracket be manufactured from stainless steel 316, to prevent possible galvanic corrosion.

It is also recommended that the supplied gasket be always fitted to ensure IP66 rating and to prevent galvanic corrosion if the mounting bracket is not manufactured from stainless steel 316.

Stainless steel 316 fixings must be used.

**Figure 1. Suggested mounting bracket and Earthing (grounding) arrangements**

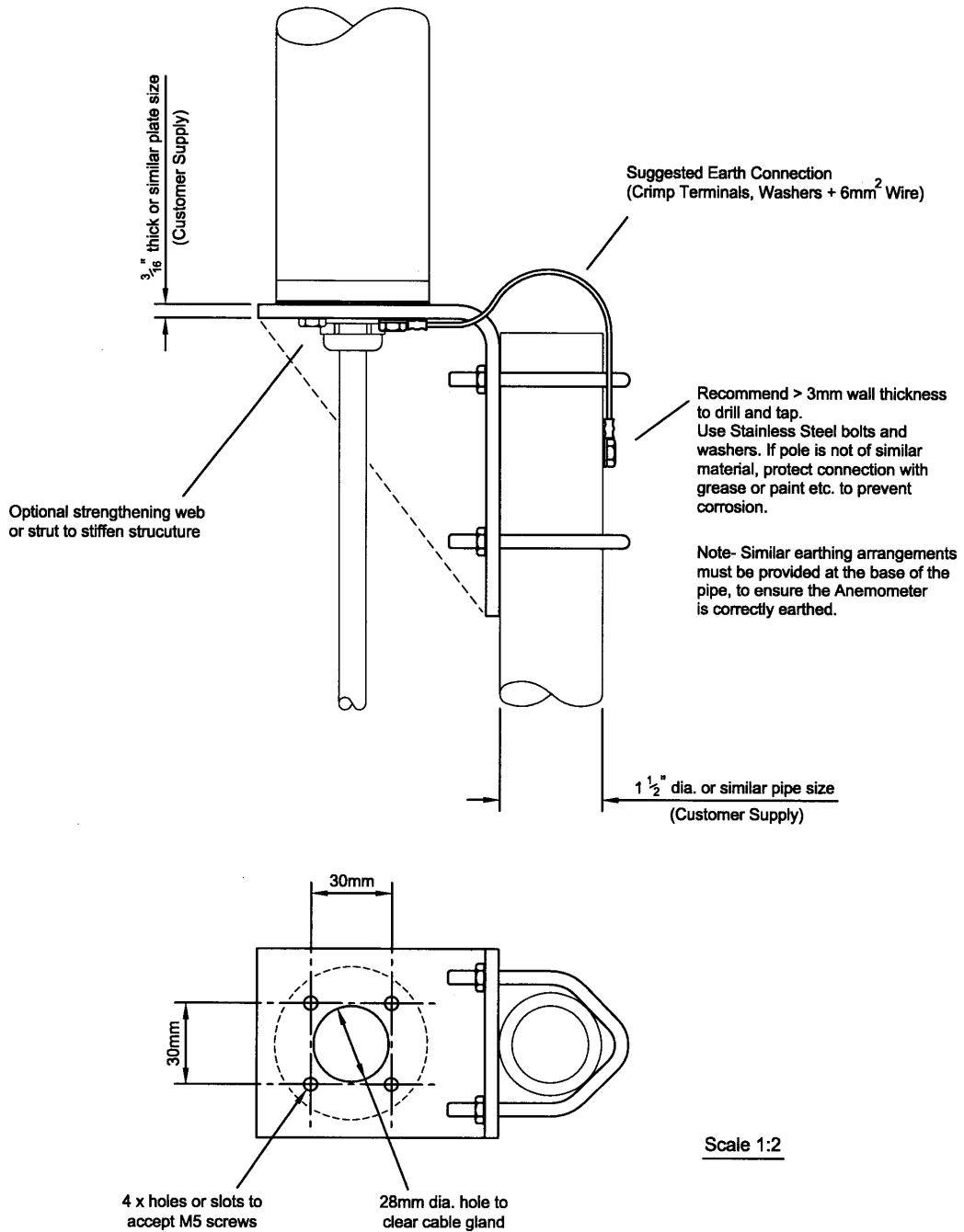

## Alignment

The anemometer should be set to point North (or to another known reference direction), using the North Spar, which can be identified from red dot alignment indicator on the base of the instrument. See *Figure 2a*.

Figure 2a North marker and UV polarity definition (UV format) and Mounting Ring

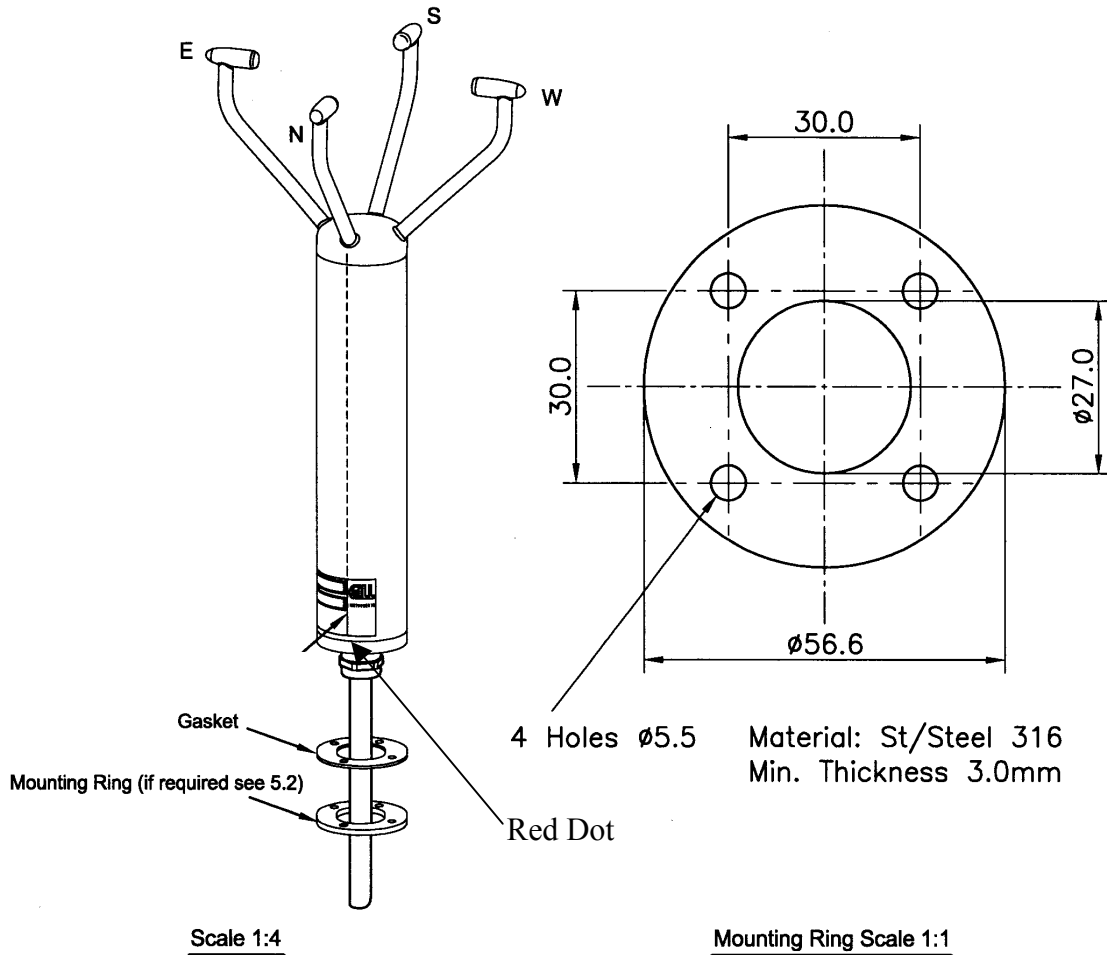
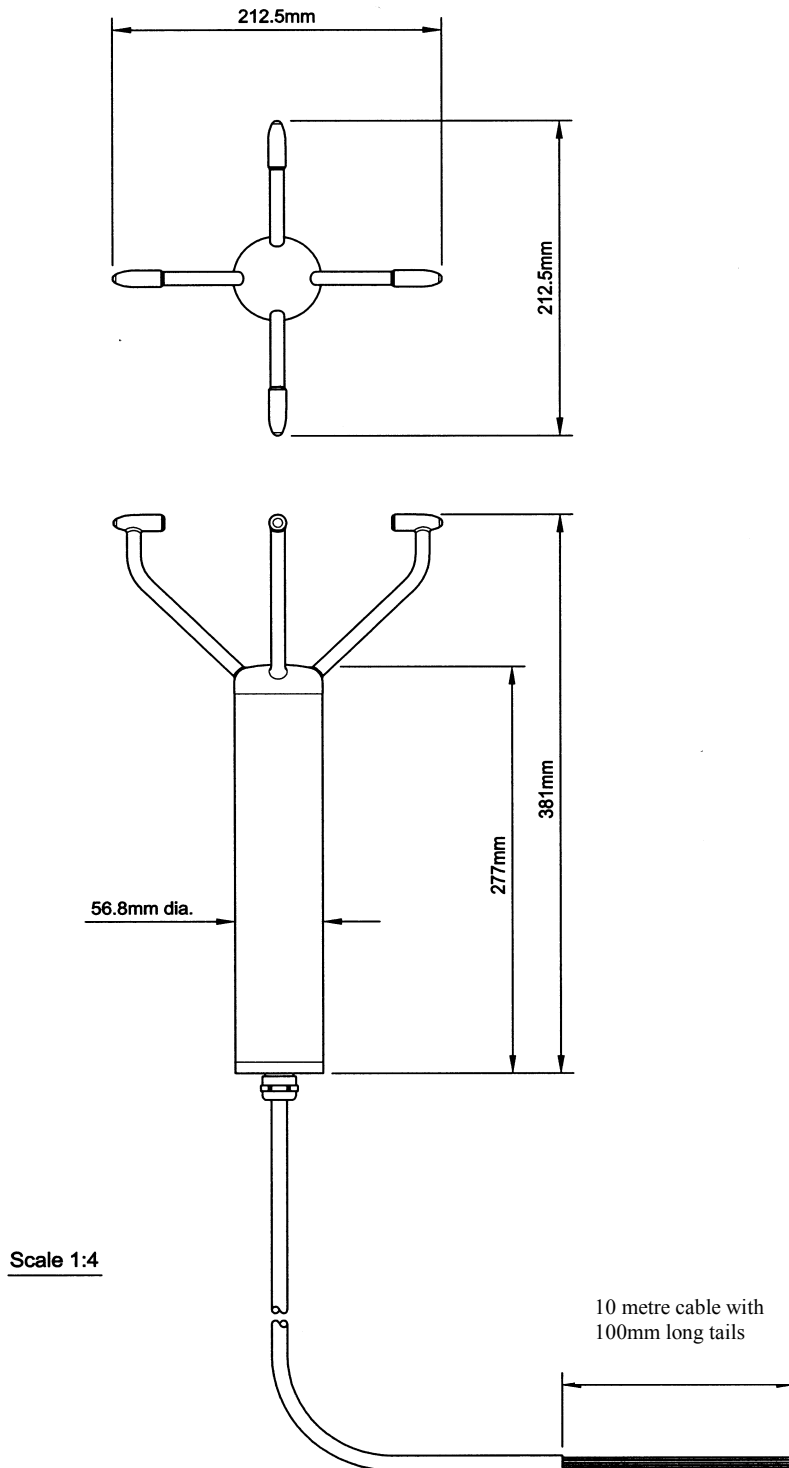

Figure 2b Aviation Standard WindObserver outline dimensions



WindObserver Overall Dimensions

## 7. USING WITH THE GILL WINDDISPLAY

The Aviation Standard WindObserver is designed to interface with the Gill WindDisplay unit to provide a complete wind speed and direction system. To interface to a non NMEA WindDisplay the WindObserver is set for Polar (M2) and 9600 (B3) configuration settings.

When coupled to a WindDisplay, the Aviation WindObserver can be used as supplied, however if a fault occurs the WindDisplay may lock into the last valid reading. Re-configuring the Aviation WindObserver to Fixed Field output (O2) will ensure that any fault is flagged on the WindDisplay.

After coupling to a WindDisplay, the Wind Speed units and the Averaging period can be selected using the WindDisplay controls. *See the WindDisplay User Manual.*

Note that although the WindDisplay can display wind speed in various units, these are calculated within the WindDisplay. The data coming to the WindDisplay **must** be in metres/sec (the factory default output setting).

**Figure 3 WindDisplay**

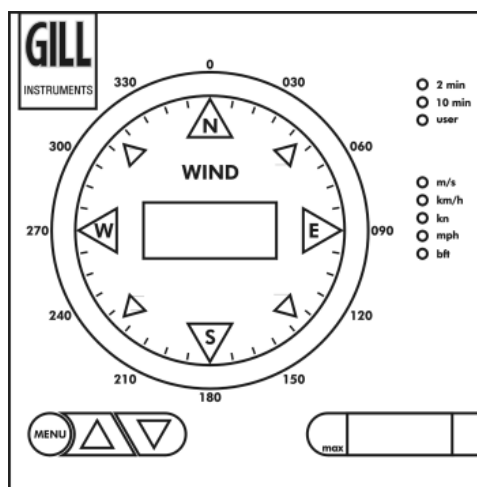

**NOTE:- If the WindDisplay is configured for NMEA mode then the Aviation Standard WindObserver must also be configured for NMEA mode and 4800-baud operation (configuration settings M5 and B2).**

## Connecting to a Gill WindDisplay

Refer to the WindDisplay User Manual for the method of operation.

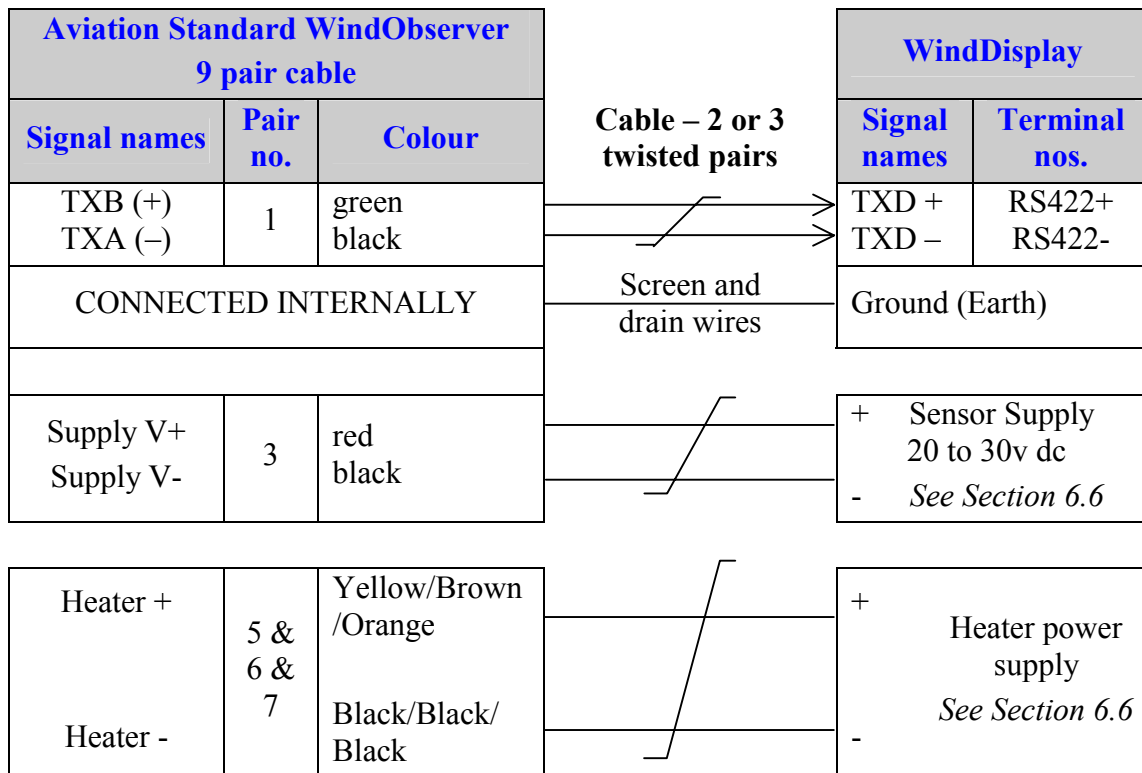

### Notes:-

Heater Pair wires Yellow, Brown and Orange should be connected in Parallel as to should the return 3 Black wires.

Heating (H command) is enabled as a default condition. If heating is required enabled then the H command must be set for H2 or H3.

See Section 9, Configuring for further details.

## 8. MESSAGE FORMATS & OPTIONS

On first applying power to the Aviation Standard WindObserver, it will be in 'Measurement Mode', and it will output wind measurement information in one of eight formats as described below.

Setting the output format, units, other parameters, options and the communication settings are all carried out in the alternative 'Configuration Mode'.

*See Section 9 CONFIGURING for details of how this is done.*

*The factory default settings are shown here in **bold**, and for convenience some 'Configuration codes' (as used to set the configuration) are shown in blue boxes. For example [M3](#).*

### 8.1. Wind Speed format

The wind speed measurements can be output in one of the following formats: UV, Polar or NMEA.

### 8.2. Output formats

The UV and Polar wind speed parameters are output in ASCII.

These parameters can be transmitted continuously or polled from the user.

Polar is also available in continuous NMEA format.

#### Output Formats Table

Output format	Output	Tri-state o/p	Configuration code
ASCII UV	Continuous	No	<a href="#">M1</a>
	Polled	Yes	<a href="#">M3</a>
ASCII <b>Polar</b>	<b>Continuous</b>	<b>No</b>	<a href="#">M2</a>
	Polled	Yes	<a href="#">M4</a>
NMEA	Continuous	No	<a href="#">M5</a>

#### Low wind speeds

Whilst the wind speed is below 0.05 metres/sec, the wind direction will not be calculated, in CSV mode no wind direction figure is shown, in Fixed Field mode the last known good direction figure is shown. All other output parameters will continue to update at the output rate.

### 8.3. Networking

#### Gill Proprietary Network

Each anemometer connected to the network **MUST** be given a unique Unit Identifier (Letters A to Z), and set to a polled tri-state mode (UV or Polar) ([M3](#) or [M4](#)).

In these modes the communications transmit line is tri-state unless the anemometer is responding to a command. If used in a multi drop system then it is recommended that Unit Identifiers A, B, C, D, E, F, K, M, N and P are not used.

#### Configuring Aviation Standard WindObserver for Half Duplex Operation.

- 1) Set up Two Terminals: One for RS485 Half Duplex and the other for RS422 Full Duplex.

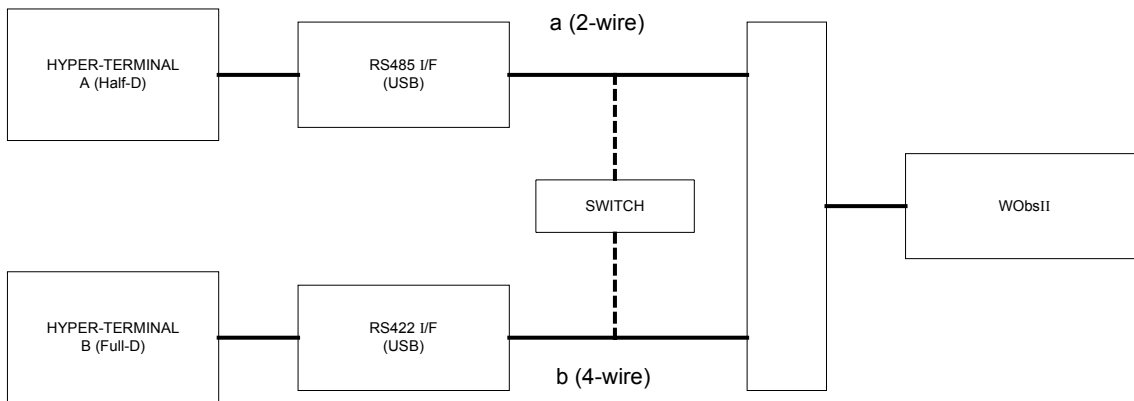

One PC (with two USB ports) can be used for both Terminals, although two may be less confusing.

Note: Power must not be disconnected from the anemometer throughout this procedure.

- 2) Assuming the unit is set for Full Duplex, connect 9-way at [b] disconnect 9-way at [a]. Set Switch to position [b] (4 wire).
- 3) On Terminal B, enter CONFIGURATION MODE. Set Half Duplex (E2). The CONFIRM> prompt will appear.
- 4) Disconnect 9-way [b] and connect 9-way [a]. Set Switch to position [a] (2 wire).
- 5) On Terminal A, type "E" <ENTER> to confirm.
- 6) The unit should now be configured in Half Duplex mode.

#### Configuring Aviation Standard WindObserver for Full Duplex Operation.

- 1) Assuming the unit is set for Half Duplex, disconnect 9-way [b] and connect 9-way [a]. Set Switch to position [a] (2 wire).
- 2) On Terminal A, type "E1" to select Full Duplex. The CONFIRM> prompt will appear.
- 3) Disconnect 9-way [a] and connect 9-way [b]. Set Switch to position [b] (4 wire).
- 4) On Terminal B type "E" <ENTER> to confirm.

## 8.4. Units

The wind speed can be set to any of the following units:

Unit	Abbreviation
Metres per sec	m/s
Knots	knots
Miles per hour	MPH
Kilometres per hour	kph
Feet per minute	fpm

## 8.5. Output rate

The output frequency can be set between 1 and 4 per second. The wind speed is sampled every 25ms, each axis being sampled sequentially. The following Table lists the possible outputs per second and the corresponding number of averaged samples. A 25ms sample period is used to process and output the results.

Outputs per Second	Sample Average
1	39
2	19
4	9

## 8.6. Averaging (Digital Data)

The Averaging Period can be set from zero to 3600 secs. (1 hour). The default setting is zero. When averaging is enabled, data is output at a rate determined by the averaging period. The data is an average of valid data collected during the averaging period. If G is set to zero then averaging settings will be disabled.

## 8.7. Heating

Heating is autonomous and requires no set-up once activated.

Upon unit switch on if heating is enabled and heater power available then a 1 minute burst of heating will occur to give confidence that the heating is functioning.

**WARNING NOTE:-**



**When heating is activated the bullet and transducer arms will get very hot and should not be handled.**

## 8.8. 45° Offset

If required, the U axis can be offset +45° to the transducer axis.

## 8.9. Vertical Output Padding

A dummy W vector is inserted to provide compatibility with any WindMaster that may be in a network.

## 8.10. ASCII message format (UV and Polar)

### ASCII UV format

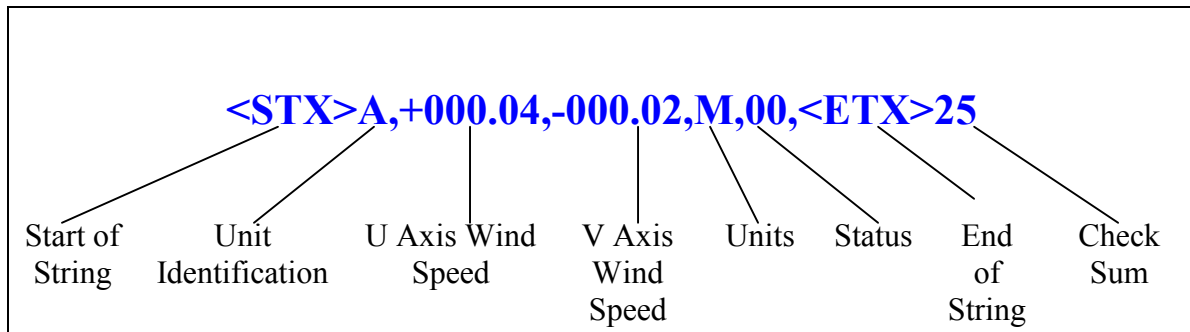

Where

**U axis wind speed**      In increments of 0.01 units ( $\pm$ UUU.UU)

**V axis wind speed**      In increments of 0.01 units ( $\pm$ VVV.VV)

<b>Units</b>	<b>Value</b>	<b>Units</b>
	M	Metres per second (m/s)
	N	Knots (knots)
	P	Miles per hour (MPH)
	K	Kilometres per hour (kph)
	F	Feet per minute (fpm)

**Start of string**      ASCII value 2

**Unit identification**      Letter A – Z (default A)

<b>Status</b>	<b>Value</b>	<b>Status</b>
	0	OK
	60 or 66	Heating enabled and OK if enabled
	Any other value	Warning or fault condition - see Section 10.5

**End of string**      ASCII value 3

**Check sum**      Exclusive OR of all characters between Start of String and End of String reported as ASCII hex.

---

## ASCII Polar format

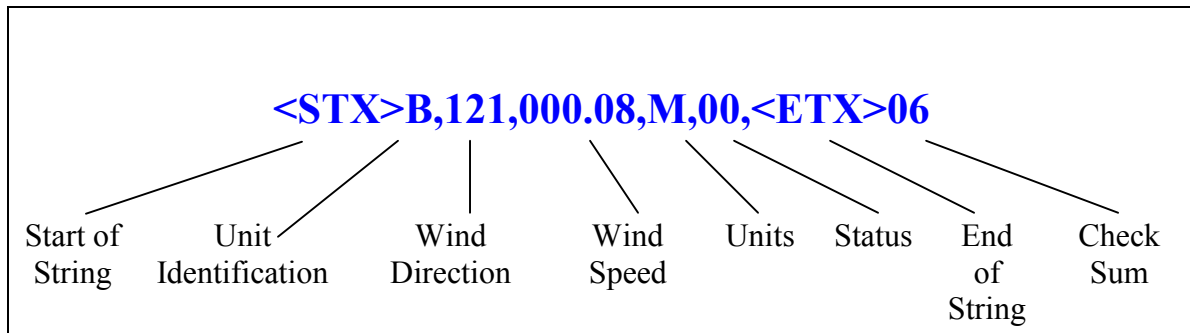

Where

<b>Wind direction</b>	In degrees relative to N (DDD)
<b>Wind speed</b>	In increments of 0.01 units ( $\pm$ MMM.MM)
All other parameters	<i>See Section 8.10 ASCII UV format</i>

## 8.11. NMEA Format

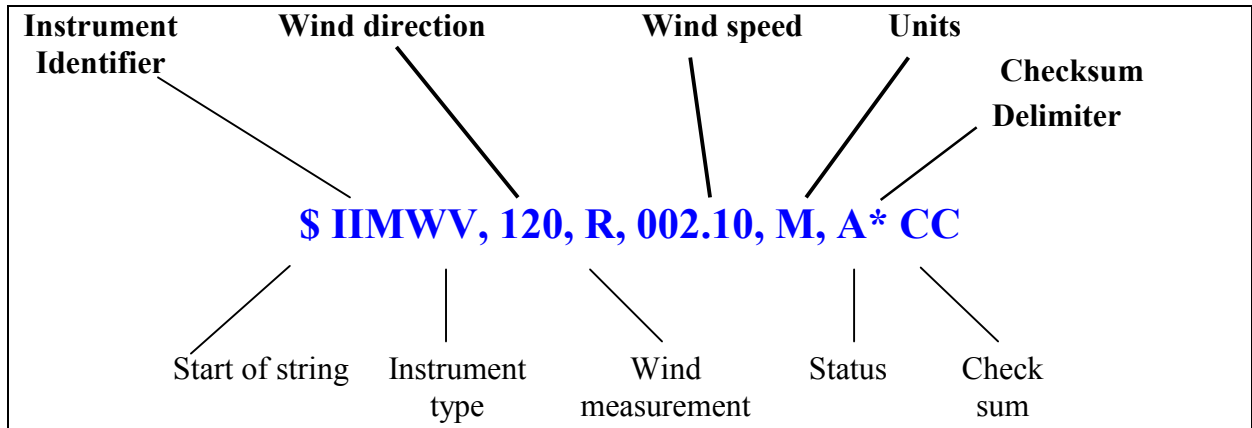

Where

<b>Wind direction</b>		In degrees relative to N (DDD)
<b>Wind speed</b>		In increments of 0.01 units ( $\pm$ MMM.MM)
<b>Units</b>	M	Metres per second (m/s)
	N	Knots (knots)
	P	Miles per hour (MPH)
	K	Kilometres per hour (kph)
	F	Feet per minute (fpm)
<b>Start of string</b>	\$	
<b>Instrument type</b>	IIMWV	
<b>Wind measurement</b>	R	Relative wind measurement
<b>Status</b>	A	Acceptable measurement
	V	Void measurement
<b>Check sum</b>		Exclusive OR of all characters between '\$' and '*' reported as ASCII hex.

A typical Aviation Standard WindObserver configuration suitable for NMEA would be:

B2, E1, F1, G0, K1, L1, M5, O1, P1, U1.

Consult specification NMEA 0183 version 3 (available on the web) [www.nmea.org](http://www.nmea.org) for complete interface details.

## 9. CONFIGURING

WindCom may be used to configure Aviation Standard WindObserver. This is an easy to use menu-driven package, available as a free download at [www.gill.co.uk](http://www.gill.co.uk).

Alternatively, you may use terminal emulator software such as HyperTerminal or Terminal.

This section describes the commands used to change settings when using terminal emulator software. *For a fuller description of the settings and options see Section 8 - Message Formats & Options*

Keystrokes are shown thus :- [Type D 3 and press ENTER](#)

### 9.1. Entering Configuration mode

#### From Continuous mode

[Type \\*](#)

#### From Polled mode

[Type \\*N](#) - where N is the Unit Identifier.

*Note - the Unit Identifier must be entered as upper-case*

The Aviation Standard WindObserver responds with a CONFIGURATION MODE message, stops reporting wind measurements, and waits for a command (as detailed below).

### 9.2. Returning to Measurement mode

[Type Q and press ENTER](#)

If in **Continuous** mode, the anemometer responds with wind measurements immediately, continuing at the selected Sampling rate.

If in **Polled** mode,

- [?](#) Enables poll
- [N](#) Polls anemometer (where N is the Unit identifier entered as upper-case)  
The anemometer replies with a single set of wind measurements
- [&](#) Anemometer replies with Unit identifier
- [!](#) Disables poll

Note:- If the unit is in Polled Mode it is always best to interrogate the unit for data with a [?](#) before the poll identifier to cater for the event that the power has been switched off or power interrupted.

If used in a multi drop system then it is recommended that Unit Identifiers A, B, C, D, E, F, K, M, N and P are not used.

### 9.3. Checking the configuration

We strongly recommend that, as a standard procedure, you use this command (**D3**) prior to, and after, changing any settings. It shows the current settings for all the alterable settings. We suggest you note down your settings, so that you can easily return to them.

**Type \*** Enters Configuration Mode (from Continuous mode)

Or **Type \* N** Enters Configuration Mode (from Polled mode)

**Type D3 and press ENTER** The Aviation Standard WindObserver responds with the current settings.

The factory default settings for a heated unit are: -

**A0 B3 C1 E1 F1 G0000 H1 J1 K1 L1 M2 NA O1 P1 T1 U1 V1 X1 Y1 Z1**

How to change these settings is explained in the following sections.

To return to Measurement mode **Type Q and press ENTER**

### 9.4. Changing settings

To change a setting, first go into Configuration mode and then refer to the sections below. Enter the Configuration code of the new setting required, followed by **ENTER**.

If successful, the new setting will be echoed back as a message by the Aviation Standard WindObserver.

For example, to change the message format to NMEA, enter **Type M5 and press ENTER**. The Aviation Standard WindObserver will reply with **M5**. When the unit is returned to the Measurement mode **Type Q and press ENTER**, it will be in NMEA format.

Note: The factory-set (default) settings are shown in **bold** in the following sections.

### 9.5. Configuration Settings

**Ax – Not Applicable**

**BX - Baud Rate**

Setting	Configuration code
2400	B1
4800	B2
<b>9600</b>	<b>B3</b>
19200	B4
38400	B5
1200	B6
300	B7

To change the Baud rate when using HyperTerminal: -  
 Eg. If set to B3 (9600 baud) and it is required to set to Baud rate to B2 (4800 baud).  
 Type \* to enter Configuration Mode.  
 Type B 2 and press ENTER, **(Do not type any further commands at this stage).**  
 Close the 9600 Baud HyperTerminal connection.  
 Open HyperTerminal and set the new connection Baud Rate to 4800 baud.  
 Type B and press ENTER, the letter B will be shown followed by Capital B2  
 Type Q and press ENTER, data will scroll at the new baud rate.

**Cx- Not applicable.****Dx- Diagnostic and Configuration Command (see also Section 10.6)**

Each of these commands causes a response from the Aviation Standard WindObserver.

Item	Command code	Typical response
Type and serial No.	D1	F9010001
Software version	D2	5.00
Unit configuration	D3	Current configuration: A0 B3 C1 E1 F1 G0000 H1 J1 K1 L1 M2 NA O1 P1 T1 U1 V1 X1 Y1 Z1
Analogue ID (if present)	D4	No analogue fitted.
Anemometer power supply voltage	D5	+29.8
Integrity check	D6	See Para 10.6 Bench Tests

## Ex - Full Duplex/Half Duplex Mode

Setting	Configuration code
Full duplex	<a href="#">E1</a>
Half duplex	<a href="#">E2</a>

Note: - Refer also to Para 8.3 Networking Configuration details.

## Fx- Data and Parity Options

Setting	Configuration code
8 bits, no parity, 1 stop bit	<a href="#">F1</a>
8 bits, even parity, 1 stop bit	<a href="#">F2</a>
8 bits, odd parity, 1 stop bit	<a href="#">F3</a>

## Gx to Gxxxx - Averaging (Digital Outputs only)

Setting	Configuration code
Averaging (Default)	<a href="#">G0000</a>

Enter the required averaging period in seconds as a four-figure number between 0000 and 3600.

## Hx - Heating

Heating is autonomous and requires no set-up once activated.

Setting	Configuration code
Disabled	<a href="#">H1</a>
Activated	<a href="#">H2</a>
Activated	<a href="#">H3</a>

H2 command selects heater fault codes 62, 63, 64 and 65.

H3 command selects heater fault codes 66, 67, 68 and 69.

## Jx - Not applicable

## Kx – NMEA Settings

Setting	Configuration code
NMEA string “IIMWV”	<a href="#">K1</a>
NMEA string “WIMWV”	<a href="#">K2</a>

## Lx - ASCII Message Terminator

Setting	Configuration code
CR LF	<a href="#">L1</a>
LF	<a href="#">L2</a>

**Mx to Mxx - Message Format**

Output format	Configuration code
ASCII UV Continuous	<a href="#">M1</a>
<b>ASCII Polar Continuous</b>	<a href="#">M2</a>
ASCII UV Polled (tri-state) *	<a href="#">M3</a>
ASCII Polar Polled (tri-state) *	<a href="#">M4</a>
NMEA Continuous	<a href="#">M5</a>

\* If units are to be networked, they MUST be given unique Unit Identifiers

**Nx - Node Address**

Item	Options	Command
<b>Node Address</b>	A... -(A to Z)	N<A>

If used in a multi-drop system then it is recommended that ID's A to F and K, M, N and P are not used, as these characters can be present in the data string.

**Ox – ASCII Output Format (Output String Padding)**

Setting	Configuration code
<b>Comma Separated Variable (CSV)</b>	<a href="#">O1</a>
Fixed Field	<a href="#">O2</a>

Example data strings:-

POLAR	NMEA
<b>CSV data changing to error status code condition.</b>	<b>CSV data changing to error status code condition.</b>
□A,235,000.77,M,60,□0A	\$IIMWV,191,R,000.55,M,A*19
□A,,M,04,□24	\$IIMWV,,R,,M,V*29
<b>Fixed Field data changing to error status code condition.</b>	<b>Fixed Field data changing to error status code condition.</b>
□A,266,000.73,M,60,□08	\$IIMWV,191,R,000.55,M,A*19
□A,999,999.99,M,04,□0A	\$IIMWV,999,R,999.99,M,V*07

**Px - Output Rate**

Outputs per second	1	2	4
<b>Configuration code</b>	<a href="#">P1</a>	<a href="#">P3</a>	<a href="#">P2</a>

**Q- Measurement Mode**

See Section 9.2.

**Tx - Not Applicable.****Ux – Digital Output Units**

Units	metres/sec (m/s)	knots (knots)	miles / hour (MPH)	kilometre/hour (kph)	feet / minute (fpm)
Configuration code	<b>U1</b>	<b>U2</b>	<b>U3</b>	<b>U4</b>	<b>U5</b>

**Vx- Vertical Output Padding**

Setting	Configuration code
Disable vertical output padding	<b>V1</b>
Enable vertical output padding	<b>V2</b>

**Xx - 45° Alignment Offset/Inverted Operation**

Setting	Configuration code	Notes
Align U axis with transducer axis	<b>X1</b>	<b>X1. Aligns U axis with North/South axis.</b>
Align U axis +45° to transducer axis	<b>X2</b>	X2. This re-aligns both U&V and polarity 45° to transducer axis.
Reverses Polar Direction	<b>X3</b>	X3 reverses reported polar direction to allow the instrument to be mounted upside down. N.B. Does NOT affect UV alignment (Mode 1, 3).
Align @ 45° from North	<b>X4</b>	X4 set polar alignment at 45 degrees from North when instrument is mounted upside down. Does NOT affect UV alignment (Mode 1, 3).

Figure 4 shows the polarity of U and V if the wind components along the U and V axis are blowing in the direction of the respective arrows.

Figure 4 UV Polarity

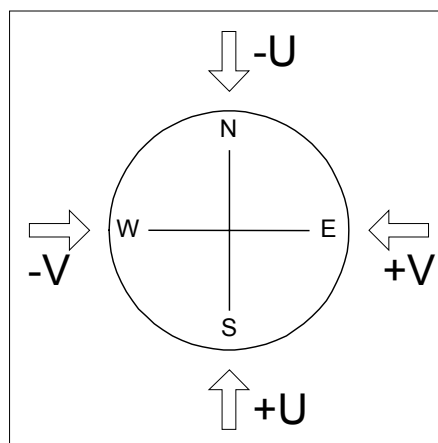
**Yx – Not Applicable.****Zx – Not Applicable.**

## 10. MAINTENANCE & FAULT-FINDING

### 10.1. Cleaning and Handling

When installing the unit handle with lint free gloves and degrease the unit to reduce the build up of deposits.

If there is any build up of deposit on the unit, it should be gently cleaned with a cloth, moistened with soft detergent. Solvents should not be used, and care should be taken to avoid scratching any surfaces. The unit must be allowed to defrost naturally after being exposed to snow or icy conditions, do NOT attempt to remove ice or snow with a tool.

**When heating is activated the bullet and transducer arms will get very hot and should not be handled.**

**Do NOT remove black “rubber” transducer caps.**

### 10.2. Servicing

There are no moving parts or user-serviceable parts requiring routine maintenance.

Opening the unit or breaking the security seal will void the warranty and the calibration.

In the event of failure, prior to returning the unit to your authorised Gill distributor, it is recommended that:

- All cables and connectors are checked for continuity, bad contacts, corrosion etc.
- A bench test is carried out as described in Section 10.6.
- Contact your supplier for advice if failure persists.

### 10.3. Fault-finding

Symptom	Solution
No output	Check DC power to Aviation Standard WindObserver, cable and connections. Check comms settings of Aviation Standard WindObserver (as detailed in Section 9) and host system match, including correct Com port Check unit is in Continuous mode Check that in-line communication devices are wired correctly. NOTE: It is usual for Anemometer TX + to be connected to converter device RX +
Corrupted output	Check comms settings of Aviation Standard WindObserver and host system match. Try a slower baud rate. Check cable lengths and type of cable.
One way communication	Check wiring is in accordance with the manual.
Failed/Incorrect output, data invalid flag	Check that transducer path is not blocked

## 10.4. Returning units

If the unit has to be returned, it should be carefully packed in the original packaging and returned to your authorised Gill distributor, with a full description of the fault condition.

## 10.5. Status (error) codes

The Status code is sent as part of each wind measurement message.

Code	Status	Condition
<b>00</b>	<b>OK Heating set off</b>	<b>Valid data, sufficient samples in average period</b>
60 (H2)	OK and heating enabled	Valid data, sufficient samples in average period
A	OK	NMEA data Acceptable
01	Axis 1 failed	Insufficient samples in average period on U axis
02	Axis 2 failed	Insufficient samples in average period on V axis
04	Axis 1 and 2 failed	Insufficient samples in average period on both axes
08	NVM error	NVM checksum failed, data could be uncalibrated.
09	ROM error	ROM checksum failed, data could be uncalibrated.
10	System gain at max.	Inaccurate data likely
50	Marginal system gain	Data valid, but marginal operation
51	Measurement average building.	Data valid but warns that average period not reached when averaging used.
62 (H2)	No power to heating module	Valid data still output
63 (H2)	Hardware fault – e.g Heater pcb faulty	Valid data still output.
65 (H2)	Warning – Heater Supply volts too high or pcb too hot.	Valid data still output.
V	NMEA data Void	Invalid data output
66 (H3)	OK and heating enabled	Valid data, sufficient samples in average period
67 (H3)	No power to heating module	Valid data still output.
68 (H3)	Hardware fault – e.g Heater pcb faulty	Valid data still output.
69 (H3)	Warning – Heater Supply volts too high or pcb too hot.	Valid data still output.

## 10.6. Bench test

Couple the Aviation Standard WindObserver to the host system and power supply, using a known working test cable.

Check that the unit is correctly configured by going into Configuration mode and using [D3](#)  
See *Section 9.3 Checking the Configuration*.

Check for normal output data, and that the Status Code is OK – 00, 60, 66 or A (for NMEA format).

If the status code is other than these, refer to Section 10.5 Status (error) codes.

Use an office fan or similar to check that the unit is sensing wind, turning the unit to simulate changing wind direction and to check that both axes are functioning.

Note that this is a quick functional test. There are no calibration adjustments; the unit is designed NOT to require re-calibration within its lifetime. Gill has provided an Integrity Check, see next page for details.

### Integrity Check Chamber (ICC)

The IC is designed to:

1. Identify any gross changes in the head geometry that would affect the performance.
2. Provide a zero wind environment to confirm the WindObserver zero calibration.

The ICC has been designed to be used in an indoor still air environment with an ambient temperature between 17°C and 23°C. When conducting the test it is important that the ICC is assembled on to the WindObserver head and not touched or moved during the test.

This test is only valid if undertaken with an ICC purchased from Gill.

Note:- The Heater supply should be disconnected or turned off when using the ICC.

## Integrity & Zero Wind Check

### Zero Wind Check

Configure your PC to run HyperTerminal and assemble the ICC by inserting the reflector cases and the two halves of the ICC onto the Aviation Standard WindObserver. The ICC must be retained using the strips provided. Then:

1. Ensure that the Aviation Standard WindObserver is set for Polar (M2) mode. For Factory default settings see section 9.3.
2. Enter Measurement Mode and Record/View data

In still air wind speed measurements should not exceed 0.03m/s. If wind speed exceeds 0.03m/s contact Gill Instruments.

## Integrity Check

Ensure the ICC is assembled correctly on the Aviation Standard WindObserver and heating supply turned off. Using HyperTerminal, enter Configuration Mode as described in Section 9.

Enter D6.

A typical report as shown below will be displayed.

```
D6
ALIGNMENT LIMITS: U=2424,2524
                  V=2434,2434
ALIGNMENT U:2474 *PASS*
ALIGNMENT V:2484 *PASS*
D6
```

If 'Refer to Manual' is shown check test temperature conditions are 17 to 23 deg C and tested under zero wind condition.

If there has been no significant changes to The Aviation Standard WindObserver head configuration then \*PASS\* will confirm correct operation.

Alterations to the head geometry can result in a \*FAIL\* or 'Insufficient Samples' message. If this occurs please contact Gill Instruments.

## 11. APPENDICES

### 11.1. Glossary & Abbreviations

Item	Meaning
CAL	Calibration
CR	Carriage Return
CRLF	Carriage Return Line Feed
CSV	Comma Separated Variable
ENG	Engineering
ESC	ESCape key on keyboard used to stop any process that is being executed
ETX	End of string character
FAC	Factory
fpm	Feet per minute
GND	GrouND
HEX	HEXadecimal
I/P	InPut
IP66	Protection Classification
KPH	Kilometres per Hour
LF	Line Feed
m/s	Metres per second
MAG	MAGNitude - scalar reference to wind speed
MAX	MAXimum
MPH	Miles per Hour
NEMA	National Electrical Manufacturers Association
NMEA 0183 (version 3)	National Marine Electronics Association standard for interfacing marine electronic navigational devices
No:	Number
NVM	Non-Volatile Memory
O/P	Output
PC	IBM compatible Personal Computer
PCB	Printed Circuit Board
POR	Power On Reset
PROCOMM	Terminal emulator software package
ROM	Read Only Memory
RS232	Communications standard

Item	Meaning
RS422	Communications standard
RS485	Communications standard
RTS	Request To Send
RX	Receive
RXD	Received Data
S/W	SoftWare
SOS	Speed Of Sound
SEC	SECond
STX	Start of string character
TERM	TERMinal
TX	Transmit
TXD	Transmitted Data
+VE	Positive
-VE	Negative
WindCom	Gill software used to configure Aviation Standard WindObserver
WRT	With Respect To

## 11.2. Guarantee

For terms of guarantee contact your supplier.

Warranty is void if the green security seal covering base nuts is damaged or broken, or the transducer caps have been damaged.

### 11.3. Principle of operation

The Aviation Standard WindObserver measures the times taken for an ultrasonic pulse of sound to travel from the North transducer to the South transducer, and compares it with the time for a pulse to travel from S to N transducer. Likewise times are compared between West and East, and E and W transducer.

If, for example, a North wind is blowing, then the time taken for the pulse to travel from N to S will be faster than from S to N, whereas the W to E, and E to W times will be the same. The wind speed and direction (and the speed of sound) can then be calculated from the differences in the times of flight on each axis. This calculation is independent of factors such as temperature.

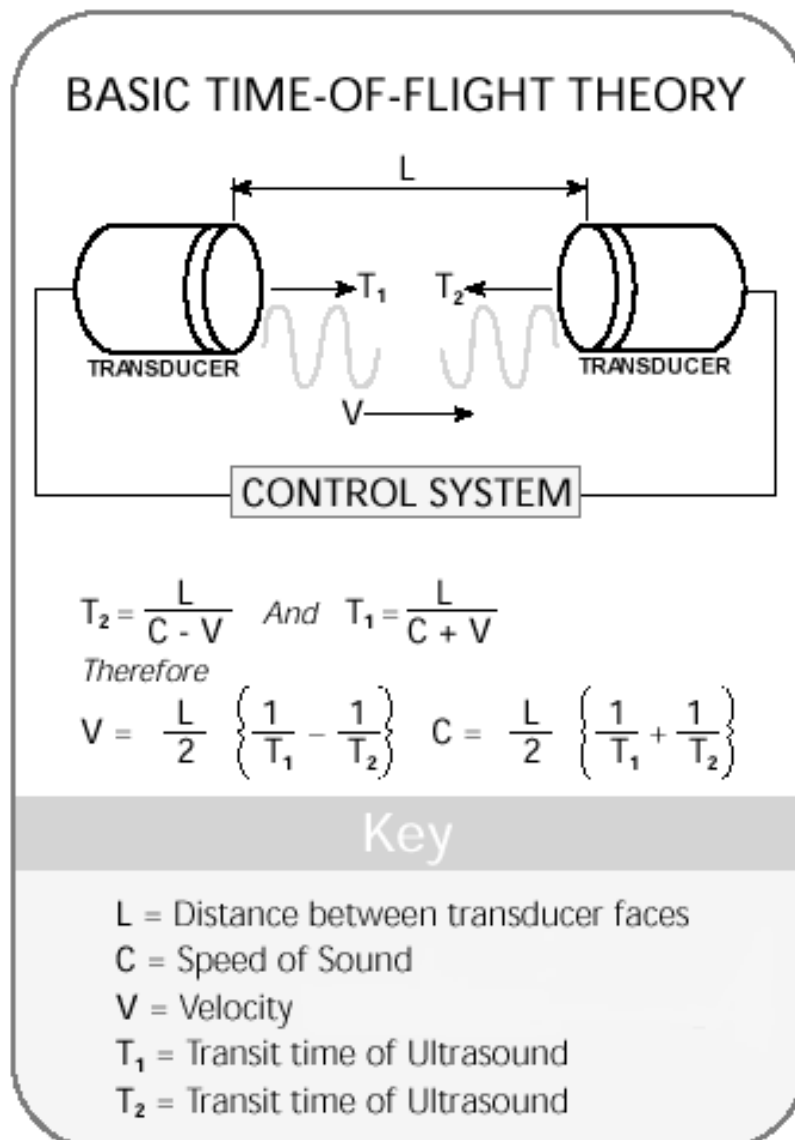

## 11.4. Electrical Conformity

### EC DECLARATION OF CONFORMITY ACCORDING TO COUNCIL DIRECTIVE 89/336/EEC



We, Gill Instruments Ltd., declare our sole responsibility that the products:

#### Aviation Standard WindObserver Ultrasonic Anemometer

Manufactured by:

Gill Instruments Ltd

Saltmarsh Park  
67 Gosport Street  
Lymington, SO41 9EG

to which this declaration relates, are in conformity with the protection requirements of Council Directive 89/336/EEC on the approximation of the laws relating to electromagnetic compatibility.

This Declaration of Conformity is based upon compliance of the product with the following harmonized standards:

EN60945:2002

EN61326:2006

Emissions

Using EN60945 and EN55011

Immunity

Using EN61000-4-2 to EN61000-4-5

EN 61000-4-6 (Excluding 150khz to 200khz Conducted Immunity)

EN 61000-4-11

A handwritten signature in black ink that reads "A.C.R. Stickland". The signature is written in a cursive style.

Signed by:

A.C.R. Stickland – Director

Date of issue:

20/03/2009

Place of issue:

Gill Instruments Ltd  
Saltmarsh Park  
67 Gosport Street  
Lymington, SO41 9EG

